

Agronomy Facts 63



Diagnosing Soil Compaction Using a Penetrometer (Soil Compaction Tester)

THE RATIONALE FOR THE PENETROMETER

Soil compaction is a serious concern for farmers in Pennsylvania. Soil compaction can easily reduce crop yields by 10 percent, and can lead to water and soil quality degradation due to increased runoff and soil structure destruction. The continuous consolidation of farms means that herds are growing, more forage is harvested per farm, more manure is being produced, larger equipment is used to spread manure and harvest and transport forages and grain, and the opportunity to tailor field operations to optimum soil conditions for traffic is decreasing. Compaction is therefore an issue that will likely increase in importance in the years to come.

There are two forms of compaction: surface and subsurface. While surface compaction can be partly alleviated with normal tillage operations, subsurface compaction below the normal tillage depth will remain. Fracturing or cutting subsurface compacted soil has, in some cases, resulted in remarkable yield increases. Many Pennsylvania producers suspect they have a subsurface compaction prob-

lem, but have no handle on how to measure it. A diagnostic tool to measure the extent and depth of subsurface compaction is a penetrometer, or soil compaction tester. This tool can help producers determine if subsoiling might be beneficial and at what depth the subsoiler should be set. Several companies sell penetrometers that are all based on the same technical specifications of the American Society of Agricultural Engineers. A penetrometer will cost around \$200.

A penetrometer consists of a 30-degree circular stainless steel cone with a driving shaft and a pressure gauge (Figures 1a and 1b). The penetrometer usually comes with two cones, one with a base diameter of 0.798 ($\frac{3}{4}$) inch for soft soils and the other with a base diameter of 0.505 ($\frac{1}{2}$) inch for hard soils. The tip is slightly wider than the driving shaft to limit friction of the shaft with the soil. The driving shaft is usually graduated every 3 inches to allow the determination of depth of compaction. The pressure gauge indicates pressure in pounds per square inch (be sure to use the appropriate scale for the tip you are using).

Figure 1a. A penetrometer, or soil compaction tester, has a graded shaft and separate reading scales for each tip. (Figure courtesy of Dickey John)

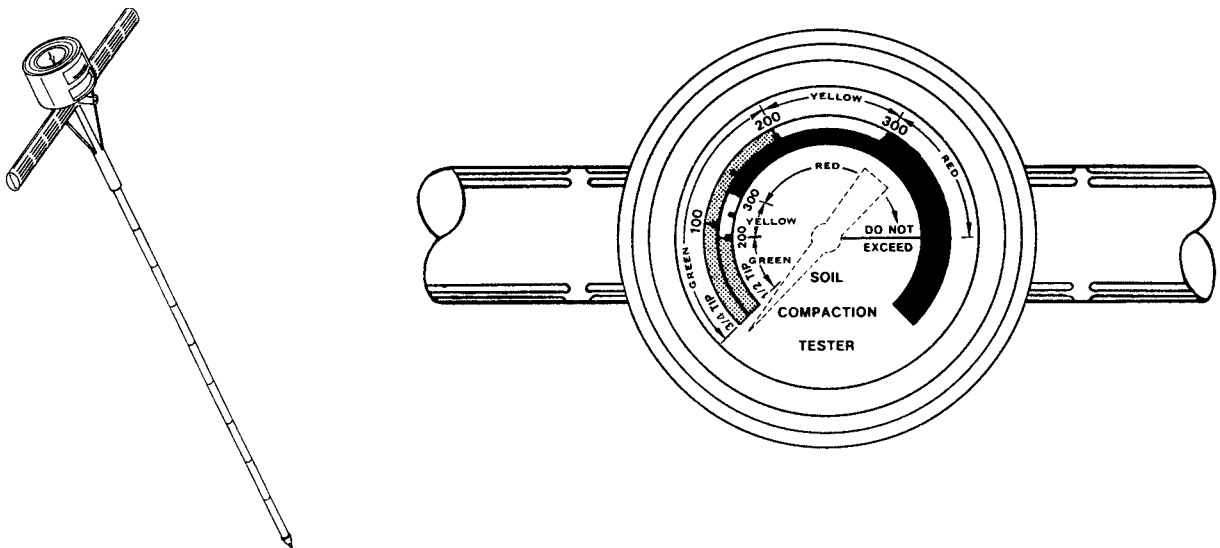
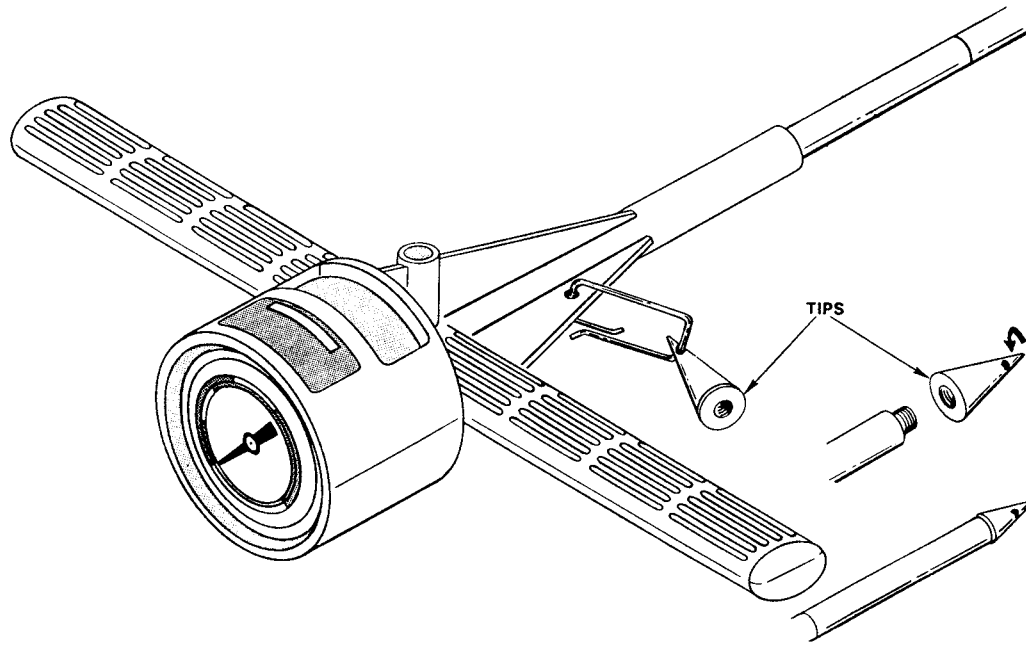

Figure 1b. A penetrometer usually comes with two points ($\frac{1}{2}$ and $\frac{3}{4}$ inch diameter). (Figure courtesy of Dickey John)



The penetrometer is designed to mimic a plant root. Of course, a plant root is living, and much smaller than a penetrometer, so the penetrometer can be expected to have some shortcomings. In studies conducted at the United States Department of Agriculture's Agricultural Research Service (USDA-ARS), root penetration into soil cores packed to different densities was measured and compared to penetrometer readings. Root penetration decreases linearly with penetration resistance, until almost no roots penetrate into soil with a penetration resistance of 300 psi (Figure 2). Much of this research was done with cotton, but it also appears to hold true for other crops. Although the limit of zero root growth may not be exactly at 300 psi, it is certain that root growth will be greatly inhibited at higher penetrometer readings. This is true in both wet and dry soils, and is independent of soil texture. Unfortunately, the penetrometer does not capture pores created by physical or biological forces such as freezing/thawing, wetting/drying, earthworm burrowing, and root channeling. Plant roots will find and grow through these spaces in the soil if they are present.

HOW TO USE THE PENETROMETER

The readings taken with the penetrometer are called the cone index. The readings should be taken when the whole profile is at field capacity (approximately 24 hours after a soaking rain). The best time of the year for the compaction measurement is the spring because the whole profile has usually been thoroughly moistened during the winter. If the soil is too wet (muddy), compaction could be underestimated because the soil acts as a liquid. If the soil is too dry, compaction could be overestimated because roots will be able to penetrate the soil when it dampens. The idea behind using the penetrometer at field capacity is that this is the best-case scenario for roots. Hopefully, the soil will be at field capacity at various times during the growing season. During these periods, roots will be able to penetrate soil that has low penetration resistance. Penetration resistance will increase when the soil dries out, and root growth can then be expected to be limited. However, when the moisture content of the soil increases again, penetration resistance will decrease, and root growth will resume.

The penetrometer rod should be driven in the soil at a rate of approximately one inch per second. As you push the penetrometer into the soil, record the depth at which the 300 psi level is exceeded, using the gradients on the penetrometer rod. This level is the top of the compacted zone. Continue pressing the penetrometer down. Record the depth at which the penetration falls below 300 psi. This is the bottom of the compacted zone. For each measuring point, there are two numbers: the top of the compaction zone and the bottom of the compaction zone. If penetration resistance never increases above 300 psi, you will have blanks in both spaces, indicating no severe root-limiting

compaction. If the penetration resistance increases above 300 psi, but never falls below 300 psi, there is no bottom to the compaction zone.

Cone index should be measured respective to tillage relief, wheel tracks, plant rows, and other recognizable patterns in the field. For example, if you know the areas of wheel traffic, take transects in and out of the track, and report them separately. If there are subsoiled zones in the field, measure penetration resistance in and out of the subsoiled zone. If there are planted rows, take measurements in and between the rows, and report them separately. Take separate readings for trafficked and nontrafficked areas.

The number of readings in a field depends on the accuracy you desire. As a first approximation, take some preliminary readings at a few places in the field to develop a sampling strategy. The cone index values are likely to be quite variable, so multiple readings are required per field. It is recommended to take one reading every 100 to 150 feet, or three to four readings per acre to develop a solid recommendation. This is a useful spacing if no recognizable patterns are present. If you recognize patterns, you may wish to increase the number of readings and report them separately as suggested above. It is extremely useful to compare the cone index values in the field with measurements in undisturbed areas such as fence rows.

After completing the sampling, a recommendation can be formulated using Table 1.

The measurement of the lower boundary of the compaction zone determines the depth of subsoiling. If subsoiling is recommended, run the subsoiler 1 inch below the compaction zone. Setting the subsoiler much deeper will not provide additional benefits. If subsoiling is done, it is important to eliminate the cause of compaction to avoid recompaction. Subsoiling should only be considered to be a measure of last resort, not an annual management practice. These recommendations are based on research conducted at the University of Kentucky. With time, we hope to validate them in Pennsylvania.

Figure 2. Root penetration and penetration resistance.

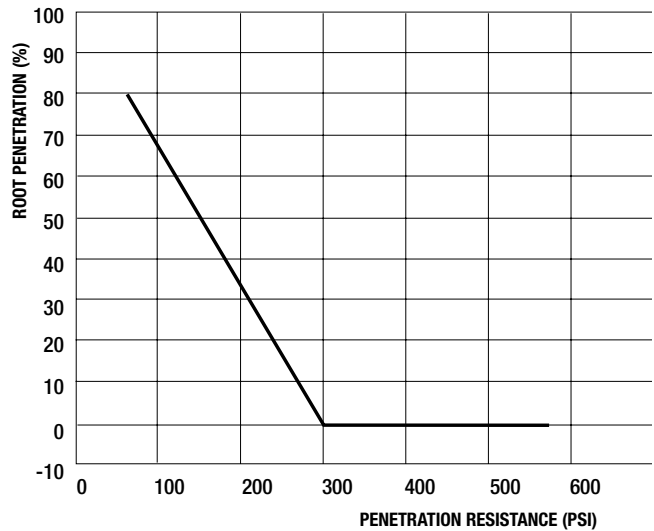

The penetrometer simulates root growth. Root growth decreases linearly with increasing penetration resistance, until practically stopping above 300 psi. Remember, however, that roots may still penetrate soil with a penetration resistance greater than 300 psi if natural cracks and pores are present.

Table 1. Interpretation of penetration resistance measurements.

PERCENTAGE OF MEASURING POINTS HAVING CONE INDEX > 300 PSI IN TOP 15 INCHES	COMPACTION RATING	SUBSOILING RECOMMENDED
< 30	Little to none	No
30–50	Slight	No
50–75	Moderate	Yes
>75	Severe	Yes

Adapted from: Lloyd Murdock, Tim Gray, Freddie Higgins, and Ken Wells, 1995. *Soil Compaction in Kentucky*. Cooperative Extension Service, University of Kentucky, AGR-161.

Prepared by Sjoerd W. Duiker, assistant professor of soil management.

extension.psu.edu

Penn State College of Agricultural Sciences research and extension programs are funded in part by Pennsylvania counties, the Commonwealth of Pennsylvania, and the U.S. Department of Agriculture.

Where trade names appear, no discrimination is intended, and no endorsement by Penn State Extension is implied.

This publication is available in alternative media on request.

Penn State is committed to affirmative action, equal opportunity, and the diversity of its workforce.

Produced by Ag Communications and Marketing

© The Pennsylvania State University 2002

Code UC178 04/14pod